

The Home Network Connection Center



Classic Series



Homeowner's Manual



Second Edition (November 1999, updated October 2000)

The following paragraph shall not apply in any jurisdiction in which such provisions are inconsistent with local law: HOME DIRECTOR, INC., PROVIDES THIS PUBLICATION "AS IS" WITHOUT WARRANTY OF ANY KIND, EITHER EXPRESS OR IMPLIED, INCLUDING, BUT NOT LIMITED TO, THE IMPLIED WARRANTIES OF MERCHANTABILITY OR FITNESS FOR A PARTICULAR PURPOSE. References to Home Director products, programs, or services do not imply that Home Director, Inc., intends to make them available outside the United States.

This publication may contain technical inaccuracies and typographical errors. The information contained herein may be revised or updated from time to time by Home Director, Inc.; any such changes shall appear in a subsequent revision of this publication. Home Director, Inc., may make modifications to its products, programs, and services at any time without notice.

Comments concerning this publication may be addressed by calling Home Director, Inc., at (800) 426-7144. The submission of comments to Home Director, Inc., establishes neither a contractual nor a confidential relationship between the submitting individual or company and Home Director, Inc. All information contained in such submissions shall become the property of Home Director, Inc., and the submitting individual or company shall retain no property rights therein.

Home Director, the Home Director logo, "The Power Behind Intelligent Living", and Network Connection Center are trademarks of Home Director, Inc. All other trademarks used in this publication are the property of their respective owners.

© 2000, Home Director, Inc. All rights reserved. Printed in U.S.A.

Notices

Notices

The Home Director Home Network Connection Center is intended for use in standard residential construction.

Federal Communications Commission (FCC) Statement

Home Director system

All components of the Home Director system have been tested and found to comply with the limits for a Class B digital device, pursuant to Part 15 of the FCC Rules. These limits are designed to provide reasonable protection against harmful interference in a residential installation. The equipment generates, uses, and can radiate radio frequency energy and, if not installed and used in accordance with the instructions, may cause interference to radio communications. However, there is no guarantee that interference will not occur in a particular installation. If this equipment does cause harmful interference to radio or television reception, which can be determined by turning the equipment off and on, the user is encouraged to try to correct the interference by one or more of the following measures:

- Reorient or relocate the receiving antenna.
- Increase the separation between the equipment and receiver.
- Connect the equipment into an outlet on a circuit different from that to which the receiver is connected.
- Consult an Authorized Home Systems Integrator for help.

Properly shielded and grounded cables and connectors must be used in order to meet FCC emission limits. Proper cables and connectors are available from Authorized Home Systems Integrators. Home Director is not responsible for any radio or television interference caused by using other than recommended cables and connectors or by unauthorized changes or modifications to this equipment. Unauthorized changes or modifications could void the user's authority to operate the equipment.

All components in the Home Director system have been tested and found to comply with the limits for a Class B CSTD device pursuant to Part 15 of FCC Rules. Operation is subject to the following two conditions: (1) this device may not cause harmful interference, and (2) this device must accept any interference received, including interference that may cause undesired operation.

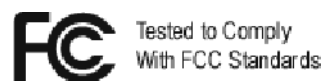

FOR HOME OR OFFICE USE

This Class B digital apparatus complies with Canadian ICES-003.

Cet appareil numérique de la classe B est conforme à la norme NMB-003 du Canada.

Option availability

Options described in this document may not be available in all models of the Home Network Connection Center. For more information about options and option availability, please contact your Authorized Home Systems Integrator.

Safety information

Your Home Network Connection Center is installed by an Authorized Home Systems Integrator with a specific configuration. If you require changes to the configuration or if you experience problems with your system, please contact your Authorized Home Systems Integrator.

To avoid possible hazards due to fire or electrical shock, only an Authorized Home Systems Integrator should install or repair the unit. If you have any questions concerning option installation, configuration, or repair, contact your Home Systems Integrator.

Sécurité

Votre centre Home Network Conneciton Center est installé, sous forme de configuration spécifique, par un intégrateur de systèmes domotiques agréé Home Director. Si vous avez besoin de modifier cette configuration ou en cas de problèmes posés par votre système, veuillez prendre contact avec l'intégrateur qui a procédé à l'installation.

Pour éviter tout risque d'incendie ou de choc électrique, seul un intégrateur de systèmes domotiques agréé Home Director est habilité à installer ou réparer l'unité. Pour toute question concernant l'installation d'options, la configuration ou la réparation, contactez

Conventions used in this book

Highlighting

There are several ways that text is highlighted in this book. Each highlighting convention has a specific purpose.

Highlight	Purpose
Bold	Bold font is used to identify items on the screen which you should click or double-click. Bold font is also used in headings, table titles, and numbered lists.
<i>Example</i>	Example font is used to show text that you need to type from your keyboard.
<i>Italic</i>	Italic font is used to show proper names of programs or books. Italic font is also used in table footnotes and sidenotes.
"Quotes"	Quotation marks are used to identify window, screen, and heading names.
<u>Underline</u>	Underline font is used to call special emphasis to a particular word or instruction.

Table of Contents

v	Notices
vi	Safety information
vi	Sécurité
vii	Conventions used in this book
vii	Highlighting
3	Introduction
3	Terms used in this manual
3	Diagram of the Home Network Connection Center
4	System overview
4	Home Network Connection Center
4	Cables and wires
5	Tap points
5	Network accessories
6	Home Network Connection Center
6	Video distribution modules
9	System modules
10	Telecom Modules
14	Other modules
17	Network tap points
19	Network accessories
19	Video camera
19	Satellite dish
23	Glossary of Terms

Chapter 1: Features and descriptions

Features and descriptions

Introduction

Terms used in this manual

This manual provides you with basic information about the features of the Home Network Connection Center. For your convenience, there is a "Glossary of Terms" on page 23. Please refer to this section for questions concerning terms used in this document.

Diagram of the Home Network Connection Center

This diagram shows how various systems and devices are connected to the Home Network Connection Center. The system you purchased may include some or all of these connections.

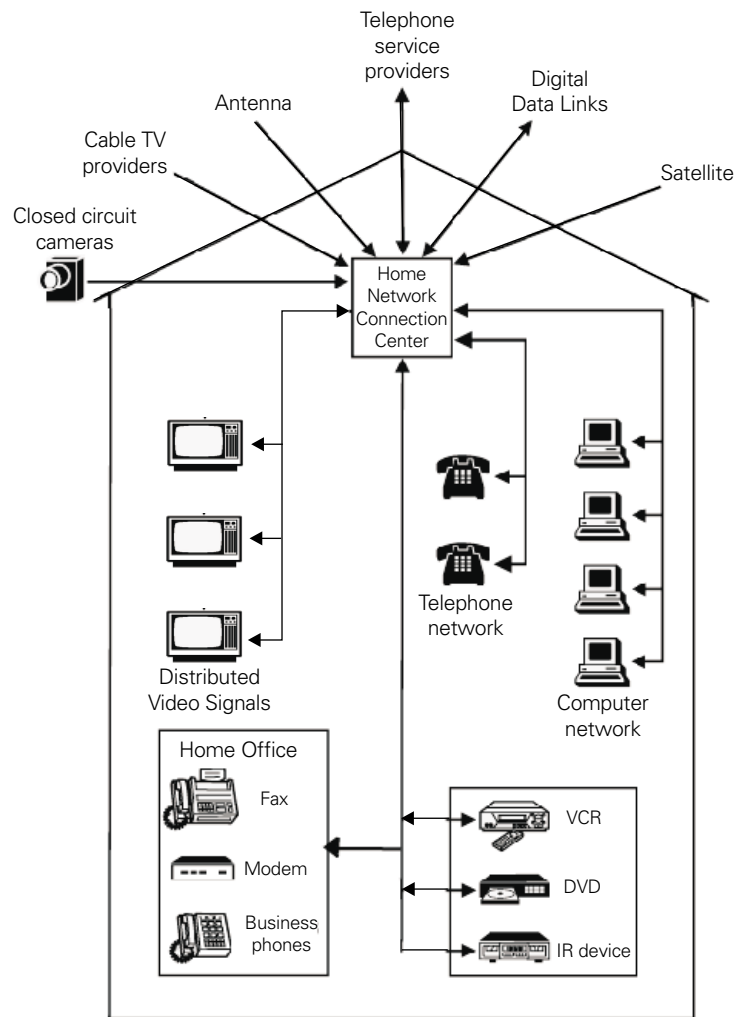

System overview

The Home Network Connection Center consists of four main network components:

- Home Network Connection Center
- Cables and wires*
- Network connections called "Tap Points"*
- Network accessories, such as video cameras*

*May be provided by your Home Systems Integrator.

Home Network Connection Center

The Home Network Connection Center links the home network together. All incoming signals generated from external sources (for example, cable TV or satellite) enter the Home Network Connection Center and are distributed throughout the network. All signals generated from internal sources (for example, CCTV or telephone) are routed to the Home Network Connection Center and are either distributed throughout the system or sent out of the home.

The Home Network Connection Center can house a 1000 Package Video/Telcom Module and a power supply. The function of the 1000 Package Video/Telcom Module is to distribute phone and video signals across the network through Category 5 twisted pair and Series 6 coaxial cables connected to it.

The Home Network Connection Center can also house either of two Video Distribution Amplifier modules (8 TAP A/B and 16 TAP) and a power supply. The function of the Video Distribution Amplifier is to distribute video signals across the network through coaxial cables connected to it. In addition to the Video Distribution Amplifier, there are other modules available for the Home Network Connection Center. These modules are described in the section labeled "System modules" on page 9.

Cables and wires

To ensure consistent and reliable data transmission, only the highest quality cables and wires are used with the Home Network Connection Center. There are two types of cables that are used in the Home Network Connection Center:

- Series 6 coaxial cables (RG-6)
- Category 5 twisted pair wires (Cat 5)

The Home Network Connection Center uses these cables and wires to distribute signals throughout your home. The RG-6 cables distribute RF modulated television and high frequency satellite signals throughout the system. The Cat 5 wires distribute telephone and data signals throughout the system for your residential and home office telephones, fax machines, modems, and other devices.

Features and descriptions

Tap points

Tap points (taps) are wall-mounted connections in various places throughout your home. These taps are connected to the Home Network Connection Center by RG-6 cables and Cat 5 wires.



Note

Options described in this document are available in all models of the Home Network Connection Center. For more information about options, please contact your Authorized Home Systems Integrator.

Network accessories

Some models may include network accessories such as satellite dishes or cameras for the television or CCTV options. Refer to “Network accessories” on page 19 for more information.

Home Network Connection Center

Your Home Network Connection Center is installed by an Authorized Home Systems Integrator with a specific installation configuration. If you require changes to the configuration or if you experience problems with your system, contact your Home Systems Integrator.

This figure shows the Home Network Connection Center with a 16 TAP Video Distribution Amplifier, Residential Telecom Module, 4 x 8 Home Office Telecom Module, Computer Networking Module, Power Distribution Module, Camera Module, and Web Point Internet Distribution Center installed.

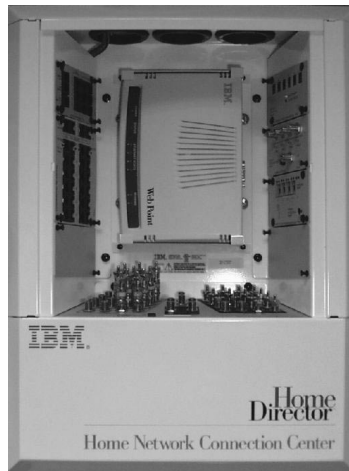

Video distribution modules

Depending on the model you selected, the Connection Center houses either a 1000 Package Video/Telcom Module, 8 TAP A/B, or 16 TAP Video Distribution Module. The characteristics of each module and the function of each cable connection is described in "Module feature descriptions" on page 8.

Features and descriptions

1000 Package Video/Telcom Module

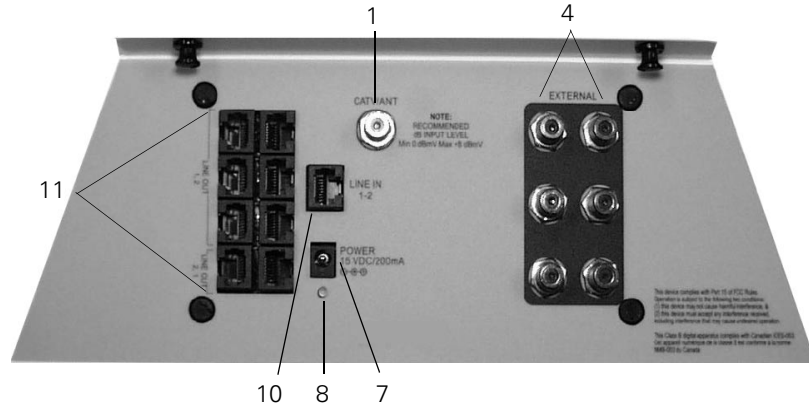

8 TAP A/B Video Distribution Amplifier

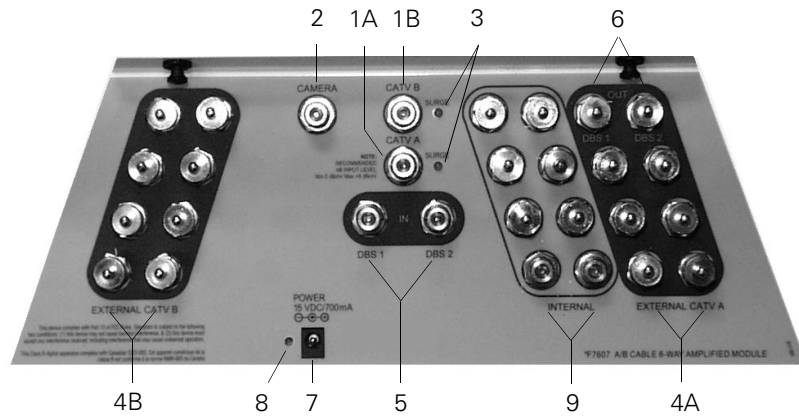

16 TAP Video Distribution Amplifier

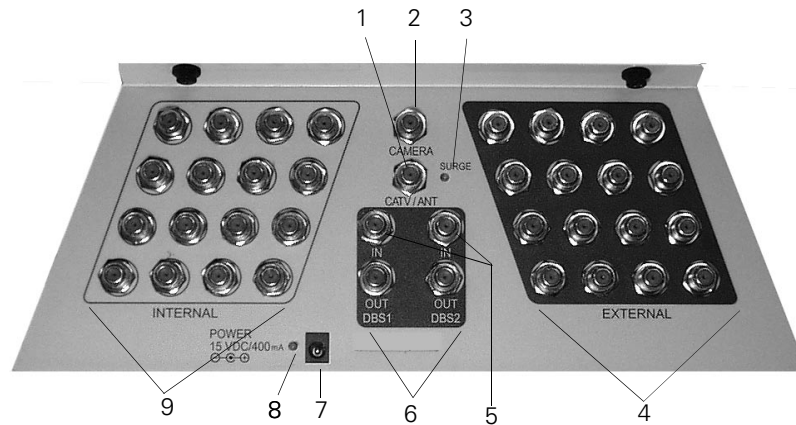

Module feature descriptions

- 1** Catv/Ant – Receives signals from your cable TV service provider or from an antenna.
 - A** Catv A - This coaxial connector is only on the 8 TAP A/B module and is for use in areas that have dual-cable access. It provides the signal input for the “A” TV cable.
 - B** Catv B - This coaxial connector is only on the 8 TAP A/B module and is for use in areas that have dual-cable access. It provides the signal input for the “B” TV cable.
- 2** Camera Port – This connector is on both the 8 TAP A/B and 16 TAP video distribution amplifier modules. This connector receives signals from the Home Network Connection Center Camera Module and distributes the signals to all external coaxial ports on the network.
- 3** Surge – This indicator is on both the 8 TAP A/B and 16 TAP video distribution amplifier modules. An illuminated red LED indicates that there was an abnormal electrical surge on your cable or antenna system. This feature is designed to protect your computer and entertainment equipment from extensive damage. If the LED is lit, contact your Home Systems Integrator to arrange service.
- 4** External Ports – These connections distribute amplified output to the video network. The cables connected to them provide the signals to TV ports located throughout your home.
 - A** Cable A External Ports - These coaxial connectors are only on the 8 TAP A/B module and are for areas that have dual-cable access. They distribute amplified “A” cable signals to TV ports throughout your home.
 - B** Cable B External Ports - These coaxial connectors are only on the 8 TAP A/B module and are for areas that have dual-cable access. They distribute amplified “B” cable signals to TV ports throughout your home.
- 5** DBS1 In/ DBS2 In - These connections are on both the 8 TAP A/B and 16 TAP modules. These connections receive input from a satellite dish. Use one for a single LNB dish and both for a dual LNB dish.
- 6** DBS1 Out/ DBS2 Out - These connections are on both 8 TAP A/B and 16 TAP modules. These connections supply the output signal from the satellite dish to one or two specified locations within your home. For example, if you have a satellite signal input at one of the IN connections [5], you may connect that cable to any one of the video cables that go out to various locations in your home. Therefore, when you connect a TV and satellite receiver to the corresponding OUT terminal, that TV is dedicated specifically for satellite signal reception. Other signals sent to the CATV/ANT port [1] or the INTERNAL connections [9] dedicate all other locations in your home specifically for those signals. Connecting cables in this fashion enables you to have televisions dedicated for either satellite reception or for the other signals (cable TV or antenna, and INTERNAL signals if provided). In the 8 TAP A/B Video Distribution Module, the DBS Out signal is only on the designated “A” cable TV signal panel and enables televisions connected to those taps to receive both cable/ antenna and satellite signals.
- 7** Power Connection – 15 volt DC power is supplied to the amplifier by the Power Distribution Module or from the junction box in the bottom of the Home Network Connection Center and is connected to this port.
- 8** Power LED – This light indicates that power is being supplied to the module.

Features and descriptions



Caution!

If your Home Network Connection Center has either a Residential Telecom Module or 4 x 8 Home Office Telecom Module, do not touch telephone cords when there is lightning in the area.

Attention!

Si votre centre de connexion domotique est doté d'un module de télécommunications résidentiel ou d'u module de télécommunications 4 x 8, ne touchez pas aux fils téléphoniques en cas d'orage.



Note

Some systems may be installed with different module versions. Check with your Home Systems Integrator for details.

- 9** Internal Ports - These connections allow modulated signals into the video network. The cables connected to them distribute signals throughout your home. Any signals transmitted to these connections are available at every external port, unless those ports are dedicated for satellite signals.
- 10** Line In 1, 2 - Available only in the Model 1000 Package Video/Telcom Module. The incoming lines from your local phone company is connected to this port.
- 11** First and Second Banks - These banks are available only on the Model 1000 Package Video/Telcom Module. These banks distribute up to two incoming residential lines to as many as eight different locations throughout the home. In addition, each port is capable of accessing both lines in various combinations, as indicated on the module face. The first number in the pair is the primary line. There are six Line 1,2 ports and two Line 2,1 ports.

System modules

The Home Network Connection Center houses various modules that have a specific function. The modules and their function are described in this section

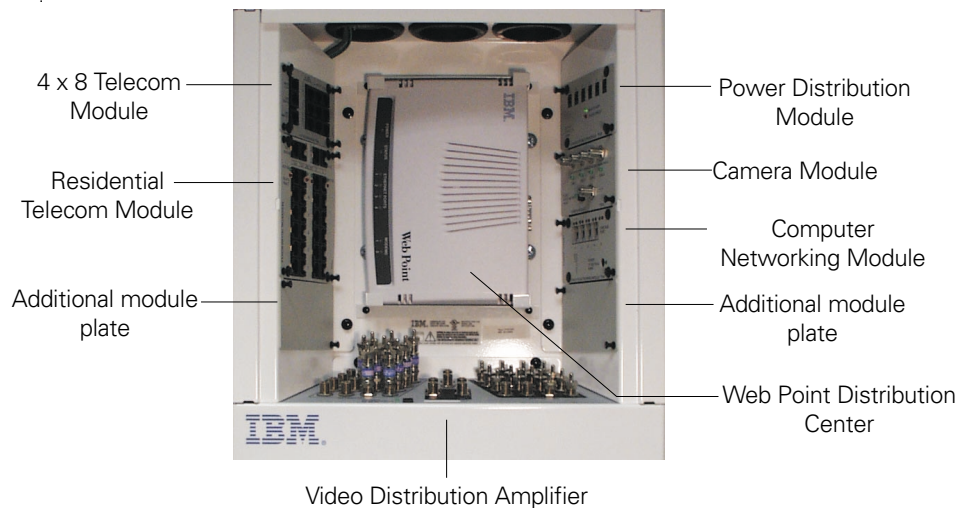

Web Point Internet Distribution Center

The Web Point Internet Distribution Center (Web Point) is an integrated analog router and four-port Ethernet hub with one 56k V.90 internal modem. It is a device that lets you set up a network of computers for simultaneous Internet access.

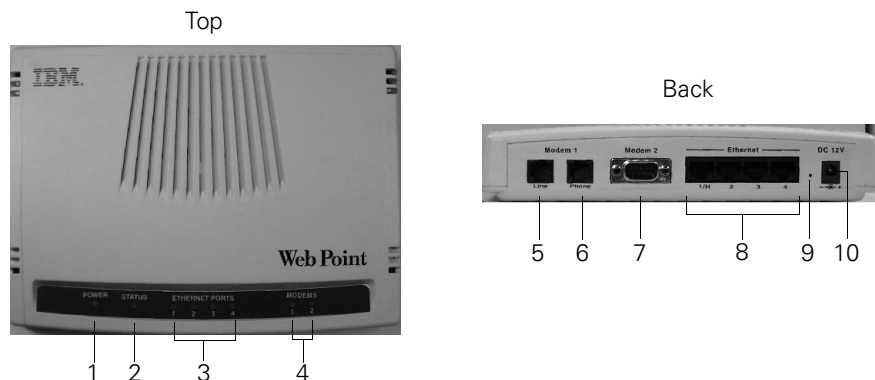

- 1 Power LED - When this light is on, it indicates that Web Point has power.
 - 2 Status LED - When this light is on, it indicates that Web Point is connected to the Internet.
 - 3 Ethernet Port LED - Each Ethernet port has an LED. When the green light is on, it indicates that port is active.
 - 4 Modem Led - The internal and the external modem each have an LED. When the light is on, it indicates that there is an active connection to that particular modem.
 - 5 Modem Line Port - This is the connector for the internal modem.
 - 6 Modem Phone Port - This is the connector for a phone line.
 - 7 External Modem Serial Connector - This 9-pin connector is for an external modem. For details on connecting and configuring an external modem, see the *Web Point Internet Distribution Center Reference* on the *EasyStart CD* included in the Web Point Internet Distribution Center package.
 - 8 Ethernet Port - There are four Ethernet ports: 1/H, 2, 3, 4.
 - 9 Reset Switch - This switch enables you to reset all the Web Point settings to the factory defaults.
- Important Note:** If you reset Web Point, all of your current settings are lost.
- 10 DC Power Input - DC power is connected to this port.



Note

Phone line configurations can be rearranged and personalized according to your needs. To reassign an individual line or combination of lines at a specific tap point location, contact your Authorized Home Systems Integrator.

Telecom Modules

Important Note: Depending upon the brand of phones you own, as well as the telephone service available in your local area, there is a limit to the number of phones that may be connected at any one time on any one line. The determination of the number of phones which may ring is dependent upon the R.E.N. (or Ring Equivalency Number). All phones have R.E.N.s (usually identified on a plate or embossed on the bottom of the phone). To determine your total R.E.N. in your household, find the R.E.N. for each phone connected to the same telephone line. Add the numbers together and this figure is your R.E.N.

A total per line R.E.N. of 5 is typically available through telephone companies for all residential service. Often, a total R.E.N. greater than 5 can be obtained without

Features and descriptions

any noticeable service disruption. However, if you experience a problem with your phone service, reduce the total R.E.N. per line to 5 or less.

There are two models of Telecom module that can be installed in the Home Network Connection Center.

Residential Telecom Module

The Residential Telecom Module distributes all residential phone and data lines to various Telecom/telephone connections throughout your home. This module distributes up to four incoming residential lines that can be distributed to as many as 24 different locations throughout your home. A high-speed data line may also be connected to this module.

The Residential Telecom Module has four line banks, or columns, on the module that are labeled 1 through 4. Standard single-line telephones have only a *primary* line available. Two-line phones may have both a *primary* and a *secondary* line available from Banks 1 and 2.

Caution!

If your Home Network Connection Center has either a Residential Telecom Module, 4 x 8 Home Office Telecom Module, or 1000 Package Video/Telcom Module, do not touch telephone cords when there is lightning in the area.

Attention!

Si votre centre de connexion de réseau domestique Home Network Connection Center est doté d'un module de communication téléphonique résidentielle, d'un module de communication téléphonique 4 x 8, ou d'un module de communication téléphonique/ vidéo 1000, ne touchez pas aux cordons téléphoniques en cas d'orage.

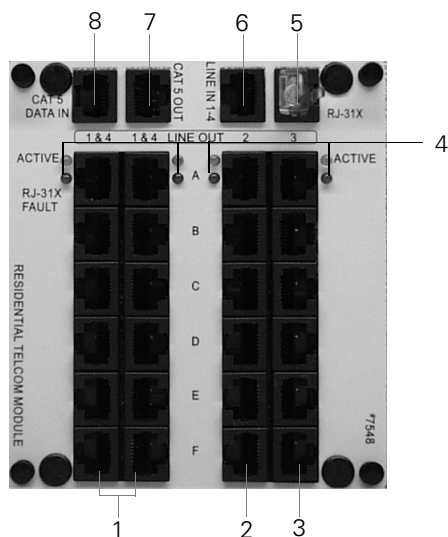

This section contains a description of the lines available at each port on the module.

- 1** First and Second Banks - These banks are designed for both single-line and two-line phone connections. For two-line phones, Lines 1 and 4 are combined in these two banks, using Line 1 as the *primary* line and Line 4 as the *secondary* line. Up to 12 different taps can be connected to these banks to access both Lines 1 and 4. Single-line phones can also be connected to these banks, but will only access Line 1.
- 2** Third Bank - Line 2 is available in this bank. Only Line 2 will be available at any tap port connected to a jack in this bank. Up to six different taps (phones) may be connected to this bank to access Line 2.
- 3** Fourth Bank - Line 3 is available in this bank. Only Line 3 will be available at any tap port connected to a jack in this bank. Up to six different taps (phones) may be connected to this bank to access Line 3.



Note

If you choose to convert a telephone data tap to an ISDN or ADSL line, that tap is no longer able to access any residential phone line.

- 4** LED Indicators – This module may be equipped with LED indicator lights. You can ignore these lights.
- 5** RJ-31X Jack - This port can be used by the company that monitors your home security system to make an emergency call using the primary phone line. Either a security panel or a shorting plug must be connected here in order to maintain a dial tone on the primary line number 1. (A shorting plug is included when the Residential Telecom Module is installed.)
- 6** Line In 1-4 - The incoming lines from the local phone company are color-coded blue (Line 1), orange (Line 2), green (Line 3), and brown (Line 4), and are carried from the service entrance through a single incoming Category 5 cable, connected to this jack.
- 7** Cat 5 Out - "Data Out" high-speed digital data service can be available at any voice/data tap point within the home either of two ways:
 - a** Installing a dedicated tap in a specific location in your house and plugging that line into the Cat 5 Out port.
 - or
 - b** Converting a residential line to a high-speed data service and plugging that line, (for example, Line 2), into the Cat 5 Out port.
- 8** Cat 5 Data In - The Residential Telecom Module supports a separate incoming Cat 5 high-speed digital data line, such as ISDN or ADSL. All Home Network Connection Centers are wired for a data line to be plugged into this port.

4 x 8 Home Office Telecom Module

The 4 x 8 Home Office Telecom Module distributes all residential phone and data lines to various Telecom/telephone connections throughout your home. This module distributes up to four incoming residential lines that can be distributed to as many as eight different locations throughout your home. Each Telecom port is capable of accessing all four lines as indicated on the module face and distributing them to all eight jacks in various locations in your home. A high-speed data line may also be connected to this module.

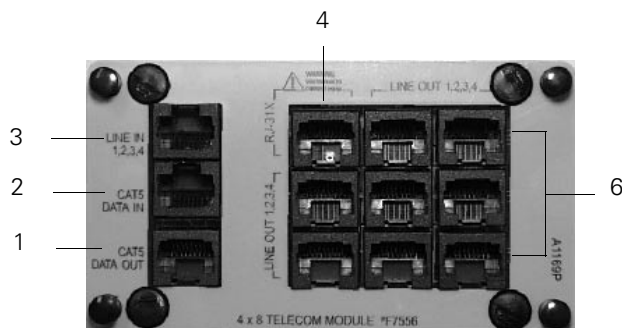

This section contains a description of the lines available at each port on the module.

- 1** "Cat 5 OUT" - "Data Out" high-speed digital data service can be available at any voice/data tap point within the home either of two ways:
 - a** Installing a dedicated tap in a specific location in the house and plugging that line into the "Cat 5 OUT" port.

Features and descriptions

or

b Converting a residential line to a high-speed data service and plugging that line, (for example, Line 2), into the Cat 5 Out port.

2 Data In - The 4 x 8 Home Office Telecom Module supports a separate incoming Cat 5 high-speed digital data line, such as ISDN or ADSL. All Home Network Connection Centers are wired for a data line to be plugged into this port.

3 Line In - The incoming lines from your local phone company are color-coded blue (Line 1), orange (Line 2), green (Line 3), and brown (Line 4), and are carried from your the Network Interface Device outside your house through a single incoming Category 5 cable connected to this jack.

4 RJ-31X Jack - This port is used by the company that monitors your home security system to make an emergency call using the primary phone line. There are two dip switches (5) that can be set to enable or disable the port.

5 RJ-31X Jack - This port can be used by the company that monitors your home security system to make an emergency call using the primary phone line. Either a security panel or a shorting plug must be connected here in order to maintain a dial tone on the primary line number 1. (A shorting plug is included when the module is installed.)

6 Line 1-4 Out - These ports support up to four lines at each wall tap (maximum of eight taps).

Telcom Module on the 1000 Package Video/Telcom Module

The 1000 Package Video/Telcom Module has an eight port telcom component that distributes a maximum of two residential phone lines to as many as eight different locations in your home.

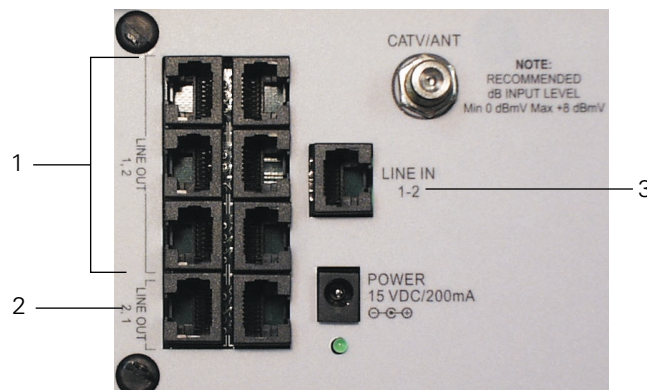

1 Line out 1,2 - These banks distribute up to two incoming residential lines to as many as six different location throughout your home.

2 Line out 2,1 - This bank distribute up to two incoming residential lines to two locations in your home.

3 Line in 1, 2 - The incoming lines from your local phone company is connected to this port.

Other modules

Camera Module

This module is available only with Home Network Connection Centers that have either an 8 TAP A/B or 16 TAP video distribution amplifier installed. The Camera Module displays the Home Network Connection Center video monitoring cameras mounted throughout your home. The module can support up to four cameras and has the following features:

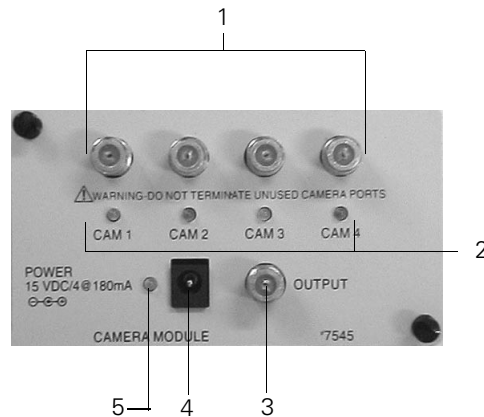

- 1** Input Ports – Each port receives a modulated signal from an individual camera.
- 2** LED Signal Indicator – This indicator allows you to quickly check camera status. A green LED light indicates an active and trouble-free camera. An unlit LED light indicates either that there is no camera assigned to that port or that the camera is inactive.
- 3** Output Port – This port sends camera signals to the video distribution amplifier module for distribution throughout your home. Camera signals can be received at all external TV connections on the network.
- 4** Power Input – 15 volt DC power is connected to this port.
- 5** Power LED - The LED lights up when power is being supplied to the module.



Warning!

Do not terminate or cap unused camera input connections. Doing so may cause damage to the module.

Avertissement!

Ne mettez pas fin aux connexions d'entrée de la caméra non utilisées, et ne les obstruez pas. Cela pourrait causer des dommages au module.

Computer Networking Module

The Computer Networking Module connects up to four computer taps located throughout your home to a network. To utilize the computer networking module, each computer to be connected to your home network requires a 10BASE-T Ethernet network interface card (available either from your Home Systems Integrator or from computer supply stores) and networking software (refer to your operating system manual for configuring your computers for network use). The module has the following features:

Features and descriptions

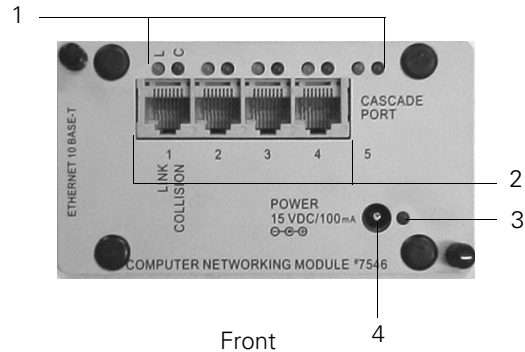

Front



Note

Your Authorized Home Systems Integrator may assist in setting up computers for network operation for an additional fee. Otherwise, refer to your computer operating system and your network card manual to configure your computers for network operation.

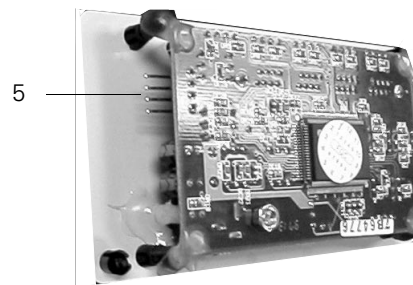

Back

- 1** Independent Link And Collision Indicators – These green and red indicators allow you to monitor the network. Green lights indicate an active and trouble-free connection. Red lights indicate a collision, meaning that the network is busy (for example, copying a large file across the network). As soon as network resources are available, the light turns green.
- 2** Network Ports – Each module can support up to four separate home computers. Each assigned port is connected to a separate computer tap.
- 3** Power LED – The LED lights up when power is being supplied to the module.
- 4** Power Input – 15VDC power is connected to this port.
- 5** Cascade Port – This port is located on the back of the Computer Networking Module and can be connected either to a second Computer Networking Module or to the Web Point Internet Distribution Center, or both. With this module you can expand your computer network to eight computers by using two networking modules or expand to seven computers by using a single networking module with a Web Point Internet Distribution Center.

Note: Up to ten computers can be networked by using two Computer Networking Modules and a Web Point Internet Distribution Center by connecting the networking modules together with the cascade port, and by connecting the Web Point Internet Distribution Center to one of the two networking module ports. This option is available through your *Authorized Home Systems Integrator*.

Power Distribution Module

The Power Distribution Module uses patch cords to distribute 15VDC power to modules that require it (for example, Computer Networking module, Camera Module, or a video distribution amplifier). The module has the following features:

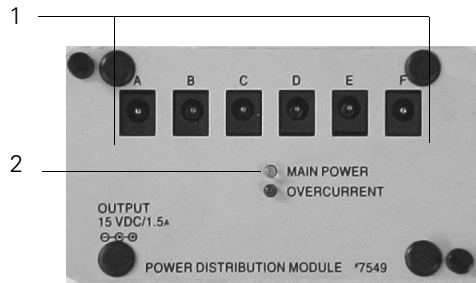

Note

Make sure the patch cords are securely plugged in. If cords are not secure, modules may not receive power.



Warning!

Do not plug devices into this unit which are not expressly approved for the Home Network Connection Center. Doing so may cause damage to the unit.

Avertissement!

Ne branchez pas des périphériques sur cet appareil qui ne sont pas expressément approuvés par le centre de connexion domotique. Cela pourrait causer des dommages à l'appareil.

- 1 Power connections – These connections, labeled “A” through “F”, connect to modules requiring power. Any module can be connected to any unused port.
- 2 Power LED – When lit, this indicates that power is available at the Power Distribution Module. The unit is protected by an automatically resetting fuse. This fuse protects your Home Network Connection Center against power surges.

If the red “OVERCURRENT” light turns on, disconnect the power cords in the Power Distribution Module that provide power to all the other modules. The red light will turn off. Reconnect the power cords to the Power Distribution Module, one at a time. When you connect the problem module, the red light will turn on again. When you identify the problem module, disconnect that module and contact your Authorized Home Systems Integrator for assistance.

Network tap points

Tap points (taps) are wall-mounted connections in various places throughout your home. These taps are connected to the Home Network Connection Center by twisted pair wires (Cat 5) or coaxial cables (RG-6). These tap points may have a variety of ports that enable you to connect various devices such as telephones, fax machines, computers, TVs, or video cameras to your Home Network Connection Center.

For example, an RJ-11 4-pin tap point for a telephone, fax machine, or computer modem provides a connection that can carry an internally generated telephone call to either an external or internal source. An RJ-45 8-pin tap point provides a connection that enables one computer to communicate to other computers that are on your home computer network. For more information about setting up a computer network, see “Computer Networking Module” on page 14.

An RG-6 coax cable tap point provides a connection that carries externally generated signals to your television set or VCR from the Home Network Connection Center. By connecting your TV to this tap point, you may be able to view externally generated TV, satellite, cable TV, or antenna signals depending on the model of video distribution amplifier you purchased.

Some types of RG-6 tap points enable you to distribute signals internally. Certain tap points can be used to send signals (such as VCR, Laser Disc, or video camera) back to the Home Network Connection Center to be distributed to other tap points in your home. For example, from the TV in the master bedroom you can watch the VCR located in your family room.

Note: Video signals sent through an internal port must be assigned to a specific channel through a modulator. The channel you select must not be used by any other source (for example, cable TV, antenna, or DBS). Here are general guidelines for using an internal port. For specific instructions, refer to the instructions that came with your modulator.

- 1 Connect the base band video connections on your VCR, video camera, or laser disc player (these connections are identified as *video out* and are typically color-coded yellow, white, and red) to the base band video input connections on a modulator.
- 2 Connect the output port of the modulator to the internal port tap point in that room. The signal is sent back through the Home Network Connection Center. You can view the signal on any TV by selecting the channel you set on the modulator.



Note

Modulators receive input from the specific device (for example, a video camera) and put the signals back onto the network on a specific channel. Modulators and necessary cables are not supplied, but are sold separately by your Authorized Home Systems Integrator.



Note

Taps shown in this manual may differ from the taps installed in your home.

All unused external taps should be terminated with a terminator of appropriate resistance. For more information, contact your Home Systems Integrator.



Multitap

Network accessories

Video camera

If your Home Network Connection Center is installed with a camera module, you can have up to four CCTV cameras mounted at designated areas (for example, front door, nursery, play area). These cameras provide high-resolution black and white or color video with audio to any TV connected to a Home Network Connection Center TV port.

Once installed, the cameras are always active. To monitor a designated area, turn on any television connected to a TV port and view the channel assigned for the desired camera. Camera channels are preset by your Home Systems Integrator. Your Home Systems Integrator should provide you with all camera channel designations.

Satellite dish

If your Home Network Connection Center is installed with a Digital Broadcast Satellite (DBS) dish, a satellite decoder box is required for each television where you want satellite reception. Decoder boxes may be available from your Home Systems Integrator or most electronic supply stores.

At the time of installation, your satellite dish should be connected directly to the video distribution amplifier in the Home Network Connection Center. Depending on the model installed, the video distribution amplifier can receive and distribute DBS video, audio, and satellite Internet services to either selected or all TV ports.

Glossary

Glossary of Terms

Term	Description
4 x 8 Home Office Telecom Module	A specialized multi-port circuit board mounted in the Home Network Connection Center that distributes all residential phone and data lines to various Telecom/telephone connections throughout your home.
10Base-T	The Ethernet standard for Local Area Networks (LANs). The 10Base-T standard (also called twisted pair Ethernet) uses twisted pair cables with maximum lengths of 100 meters. The system operates at 10 Mbps and uses base band transmission methods.
10Base-T cable connectors	Specialized connectors (8-pin RJ-45) that are at the ends of a Cat 5 wire.
10Base-T Network Interface Card	A specialized printed circuit board that plugs into a computer. It enables a computer to communicate with other computers or devices on a LAN.
ADSL	Asymmetric Digital Subscriber Line. A high-speed telephone line for Internet, intranet, and remote LAN access. Available in some areas.
Camera Module	A specialized printed circuit board mounted in the Home Network Connection Center that controls video monitoring cameras.
Cascade port	A specialized port located on the back of the Computer Networking Module or a Web Point Internet Distribution Center that can expand network capacity to a maximum of 10 computers.
Category 5 wire	Wires that transmit information in a computer network or telephone system. Cable is twisted pair, and each end of the wire has an 8-pin RJ-45 connector. One end plugs into a computer network card or telephone, and the other end plugs into computer or telephone tap mounted in a wall. Also called Cat 5 wire.
CCTV	Closed circuit television
Coaxial cable	Electrical cables designed to transmit radio frequency (RF) modulated television and high frequency satellite signals throughout the system. Also called RG-6 cable.

Term	Description
Collision	The result of two workstations trying to use a shared portion of a Cat 5 cable simultaneously. The signals “bump” into each other disrupting both signals. This disruption is represented by a red light at the Computer Networking Module. If a collision occurs, the signals are automatically transmitted again. The entire process takes less than one second, and then the collision light turns green.
Computer network	A number of computers, printers, scanners, and other computer devices that communicate with one another through Cat 5 cabling and a shared protocol, such as Ethernet.
Computer Network Module	A specialized printed circuit board on the Home Network Connection Center that can connect up to four computers.
DBS	Direct Broadcast Satellite. A satellite system used in transmitting TV signals received by home satellite dishes.
Diplexer	A device used to split combined incoming video signals according to frequency. It enables more than one video signal to be sent to a TV by assigning a signal to a specific channel. For example, high-frequency satellite signals may be assigned to one channel and low-frequency TV signals may be assigned to another channel.
Ethernet	A specific type of LAN protocol. Ethernet is a widely implemented LAN protocol.
ISDN	Integrated Services Digital Network. A high-speed telephone line for transferring large amounts of data at high speeds (144K).
LAN	A local area data communications network spanning a limited geographical area (typically within a building). A LAN enables you to share disks, files, printers, and other devices under a form of standard control.
LED	Light Emitting Diode. Small lights (usually red, green, or yellow) that indicate electrical activity. LED indicators are on many of the modules in the Home Network Connection Center.
LNB	Low Noise Blocking Filter located on a satellite disk.
1000 Package Video/Telcom Module	A combination video amplifier and phone module mounted in the Home Network Connection Center that receives and transmits video and voice signals across the home network.
Module	A specialized printed circuit board used for a specific purpose.
Modulator	A device used to assign video signals to specific channels.
Off-hook	When a phone is in use, or off the hook.

Term	Description
On-hook	When a phone is not being used.
Power Distribution Module	A specialized printed circuit board mounted in the Home Network Connection Center that distributes 15VDC power to modules that require it.
Residential Telecom Module	A specialized multi-port circuit board mounted in the Home Network Connection Center that distributes all residential phone and data lines to various Telecom/telephone connections throughout your home.
R.E.N.	Ring Equivalency Number is the number of phones that can be connected at any one time and is usually found on the bottom plate of the phone. The R.E.N. varies according to the make and model of phone, as well as the phone service available.
RF	Radio Frequency
Surge	An unusual increase in the current transmitted along an electrical line, which may happen during thunderstorms or other abnormal electrical events.
Tap	A specialized wall-mounted outlet (for example, phone, computer, or video).
Video Distribution Amplifier	An 8 A/B, 16 TAP, or 1000 Package Video/Telcom module mounted in the Home Network Connection Center that receives, amplifies, and transmits signals across the Home Network.
Web Point Internet Distribution Center	An integrated analog router and 4-port Ethernet hub with one 56k V.90 internal modem. It is a device that enables you to set up a network of computers for simultaneous Internet access.

Home Director, Inc.

1015 Aviation Parkway, Suite 100
Morrisville, NC 27560
1.800.426.7144
www.homedirector.com